



GAS SPRINGS



AZOL 
GAS



DN DAMPED GAS SPRINGS

- Damped effect at end stroke
- Low force increase at initial stroke
- Smooth and uniform acceleration
- Reduced wear on both press and tool
- Low vibrations
- Improved quality part transfer



DN ISO

DAMPED AT STROKE FINAL MILLIMETERS

MODEL	F ₀	∅	S	L1	P _{max}	Charge Port		
DN 750	750	∅50	12.7 - 300	120.4 - 695	150	G1/8"	<input checked="" type="checkbox"/>	<input checked="" type="checkbox"/>
DN 1500	1500	∅75	12.7 - 300	135.4 - 710	150	G1/8"	<input checked="" type="checkbox"/>	<input checked="" type="checkbox"/>
DN 3000	3000	∅95	12.7 - 300	145.4 - 720	150	G1/8"	<input checked="" type="checkbox"/>	<input checked="" type="checkbox"/>
DN 5000	5000	∅120	12.7 - 300	165.4 - 740	150	G1/8"	<input checked="" type="checkbox"/>	<input checked="" type="checkbox"/>
DN 7500	7500	∅150	12.7 - 300	180.4 - 755	150	G1/8"	<input checked="" type="checkbox"/>	<input checked="" type="checkbox"/>
DN 10000	10000	∅195	12.7 - 300	185.4 - 760	150	G1/8"	<input checked="" type="checkbox"/>	<input checked="" type="checkbox"/>

				MODEL	SERIES
50 mm	∅50	L1=138 L1=152	1000 1000	CW 1000 KZ 1000	MINI
50 mm	∅50	L1=138	1000	AS 1000	COMPACT HEIGHT
50 mm	∅50	L1=138 L1=150 L1=150	1000 1000 750	CT 1000 CK 1000 FD 750	THREADED
50 mm	∅50	L1=170 L1=185 L1=195	750 1000 1000	GN 750 CM 1000 CD 1000	LOW PROFILE
50 mm	∅50	L1=195	750	AG 750 DN 750	HEAVY DUTY
50 mm	∅50	L1=165 L1=175	1700 2000	CPH 1700 CP 2000	ISO
50 mm	∅50	L1=220	1800	CS 1800	HEAVY LOAD
					POWER COMPACT STROKE

DN 750

150 DAMPED AT STROKE FINAL MILLIMETERS

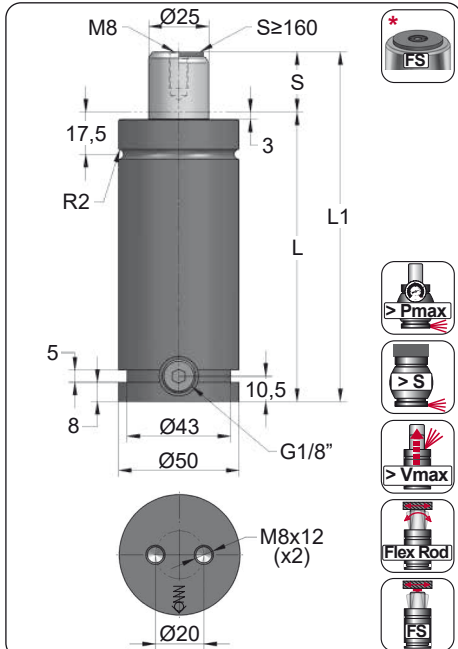

ORDER	S (mm)	L1 ±0,25 (mm)	L (mm)	Kg.
DN 750 012	12.7	120.4	107.7	1.27
DN 750 025	25	145	120	1.37
DN 750 038	38	171	133	1.48
DN 750 050	50	195	145	1.58
DN 750 063	63.5	222	158.5	1.69
DN 750 080	80	255	175	1.83
DN 750 100	100	295	195	1.99
DN 750 125	125	345	220	2.19
DN 750 160 *	160	415	255	2.48
DN 750 200 *	200	495	295	2.81
DN 750 250 *	250	595	345	3.22
DN 750 300 *	300	695	395	3.63

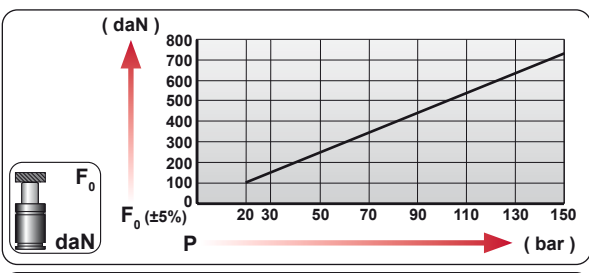

CODE	Pressure (bar)	Pressure (psi)	Force (daN)	Force (daN)
DN 750 050	150	2175	740	1100

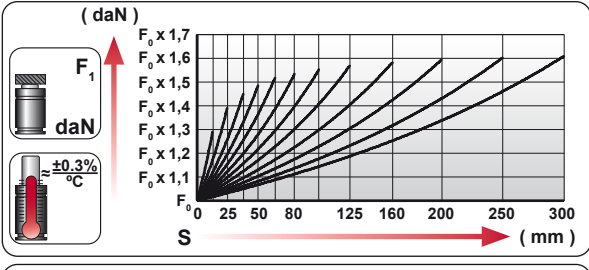

ENG ORDER
 DEU BESTELLUNG
 FRA COMMANDE
 ITA ORDINE
 ESP PEDIDO
 POR PEDIDO

F₀ daN
 S mm
 DN 750 50
 DN 750 050

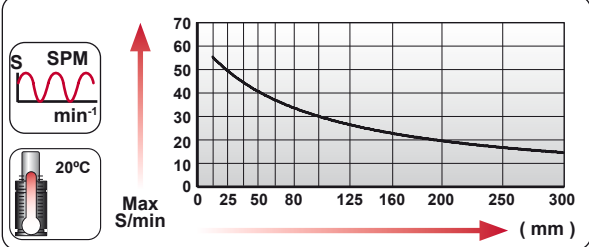

N₂ S_{max} < 90% V_{max} 2 m/s P_{min} (20°C) P_{max} (20°C) T_{min} T_{max}

N ₂	S _{max} < 90%	V _{max} 2 m/s	bar psi 20 290	bar psi 150 2175	°C °F 0 32	°C °F 80 176	600 CP-
----------------	------------------------	------------------------	----------------	------------------	------------	--------------	---------

AZOL GAS DN 750

150 DAMPED AT STROKE FINAL MILLIMETERS

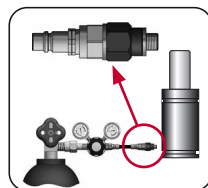
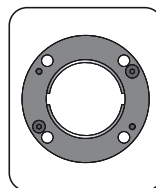
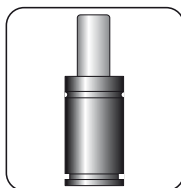

CODE	DN 750 050	KIT S-XXXXXXX KIT C-XXXXXXX	A14-050	18 CG 1-Q
ENG ORDER	GAS SPRING	REPAIR KIT	FLANGE	CHARGING ADAPTER
DEU BESTELLUNG	GASDRUCKFEDER	ERSATZTEILSATZ	FLANSCH	LADEADAPTER
FRA COMMANDE	RESSORT À GAZ	KIT DE RÉPARATION	BRIDE	RACCORD DE CHARGE
ITA ORDINE	CILINDRO AD AZOTO	KIT DI MANUTENZIONE	FLANGE	ADATTATORE DI CARICO
ESP PEDIDO	RESORTE DE GAS	KIT DE REPARACION	BRIDA	ADAPTADOR DE CARGA
POR PEDIDO	CILINDRO DE GÁS	KIT DE MANUTENÇÃO	FLANGE	ADAPTADOR DE CARGA

DN 750 MOUNTS

150

**AZOL
GAS**

A14-050



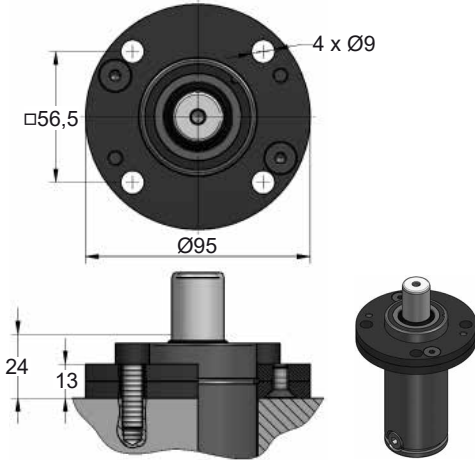

 E24.54.815.G
EM24.54.700.F

A34-050

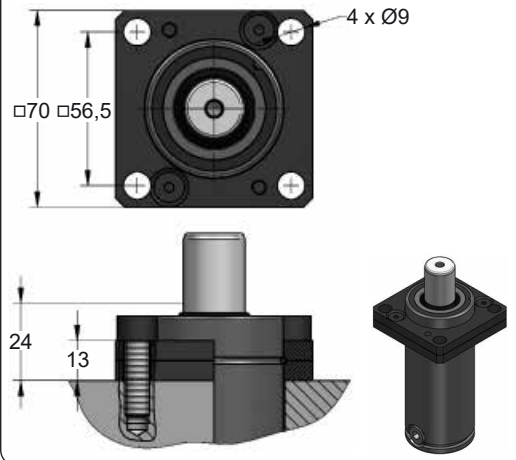

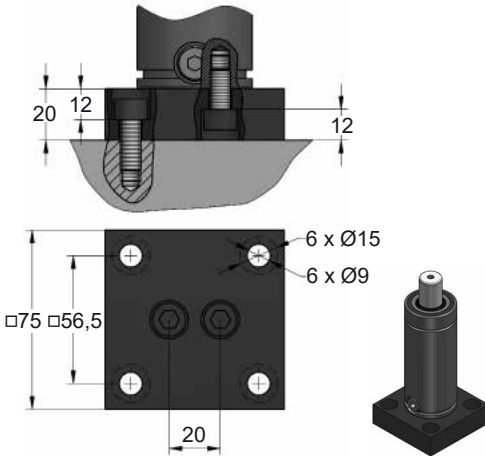

B21-050

 EM24.54.700.F

B76-050

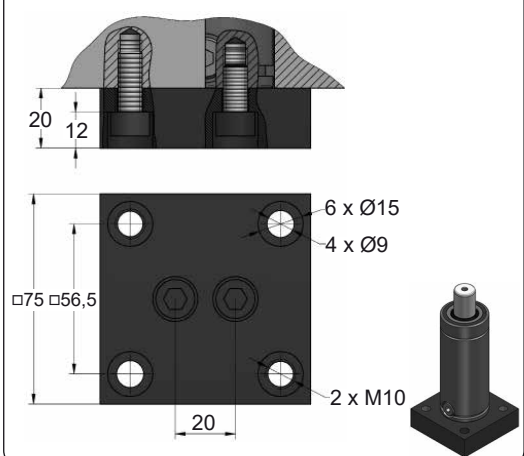

 E24.54.815.G
EM24.54.700.F

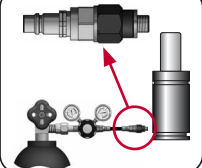
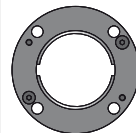
**SEAL
KIT S-XXXXXXX**

**CARTRIDGE
KIT C-XXXXXXX**

CODE
DN 750 050
**KIT S-XXXXXXX
KIT C-XXXXXXX**
A14-050
18 CG 1-Q

 ENG ORDER
 DEU BESTELLUNG
 FRA COMMANDE
 ITA ORDINE
 ESP PEDIDO
 POR PEDIDO

 GAS SPRING
 GASDRUCKFEDER
 RESSORT À GAZ
 CILINDRO AD AZOTO
 RESORTE DE GAS
 CILINDRO DE GAS

 REPAIR KIT
 ERSATZTEILSATZ
 KIT DE RÉPARATION
 KIT DI MANUTENZIONE
 KIT DE REPARACION
 KIT DE MANUTENÇÃO

 FLANGE
 FLANSCH
 BRIDE
 FLANGE
 BRIDA
 FLANGE

 CHARGING ADAPTER
 LADEADAPTER
 RACCOD DE CHARGE
 ADATTATORE DI CARICO
 ADAPTADOR DE CARGA
 ADAPTADOR DE CARGA



DN 750 MOUNTS

150

C05-050

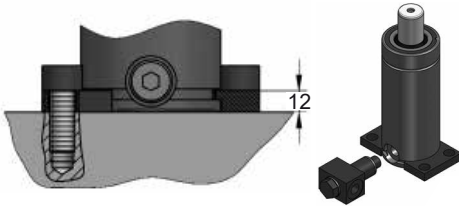
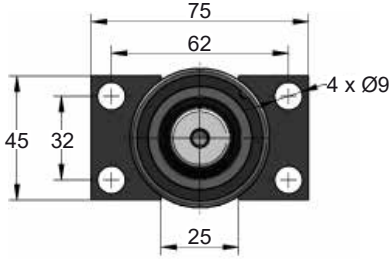

C20-050

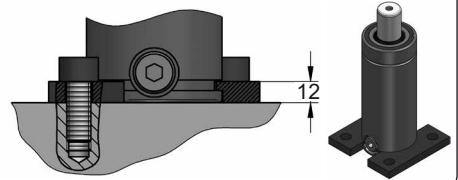
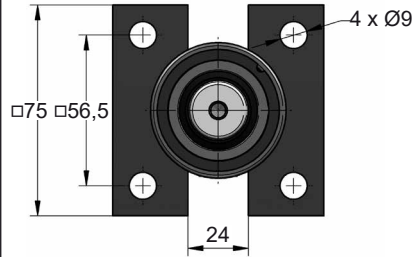

D02-050

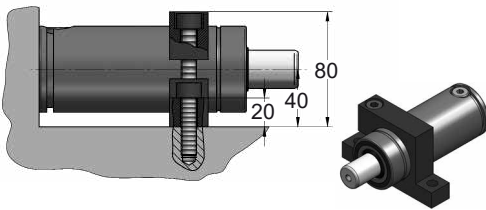
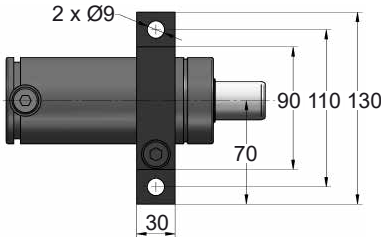

D67-050

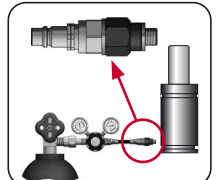
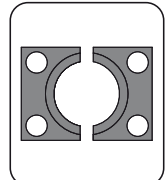
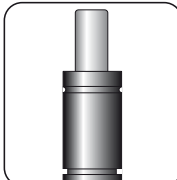
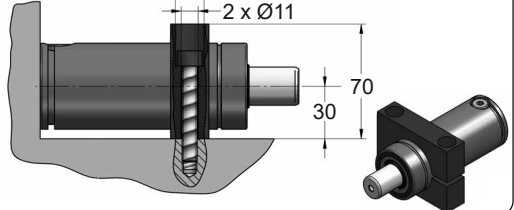
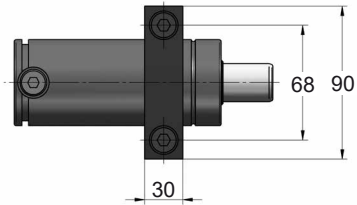

CODE	DN 750 050	KIT S-XXXXXXX KIT C-XXXXXXX	C05-050	18 CG 1-Q
ENG ORDER	GAS SPRING	REPAIR KIT	FLANGE	CHARGING ADAPTER
DEU BESTELLUNG	GASDRUCKFEDER	ERSATZTEILSATZ	FLANSCHEN	LADEADAPTER
FRA COMMANDE	RESSORT À GAZ	KIT DE RÉPARATION	BRIDE	RACCORD DE CHARGE
ITA ORDINE	CILINDRO AD AZOTO	KIT DI MANUTENZIONE	FLANGE	ADATTATORE DI CARICO
ESP PEDIDO	RESORTE DE GAS	KIT DE REPARACION	BRIDA	ADAPTADOR DE CARGA
POR PEDIDO	CILINDRO DE GÁS	KIT DE MANUTENÇÃO	FLANGE	ADAPTADOR DE CARGA

DN 1500

150 DAMPED AT STROKE FINAL MILLIMETERS

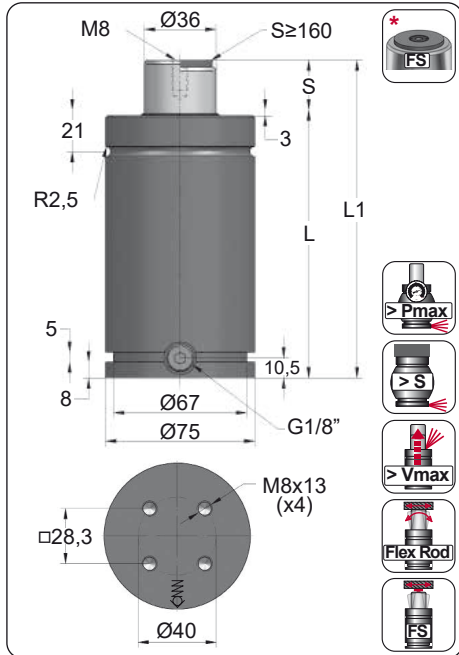

ORDER	S (mm)	L1 ±0,25 (mm)	L (mm)	Kg.
DN 1500 012	12.7	135.4	122.7	3.11
DN 1500 025	25	160	135	3.29
DN 1500 038	38	186	148	3.48
DN 1500 050	50	210	160	3.65
DN 1500 063	63.5	237	173.5	3.85
DN 1500 080	80	270	190	4.09
DN 1500 100	100	310	210	4.38
DN 1500 125	125	360	235	4.75
DN 1500 160 *	160	430	270	5.26
DN 1500 200 *	200	510	310	5.85
DN 1500 250 *	250	610	360	6.58
DN 1500 300 *	300	710	410	7.31

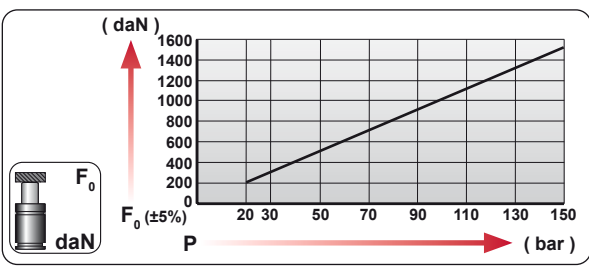

CODE	Pressure (bar)	Pressure (psi)	F ₀ (daN)	F ₁ (daN)
DN 1500 050	150	2175	1530	2070

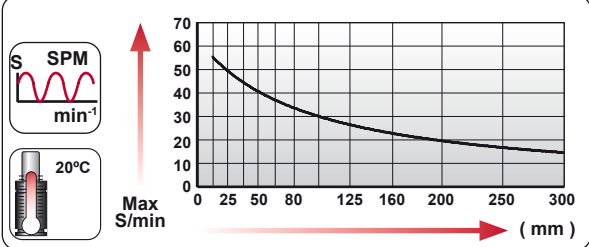
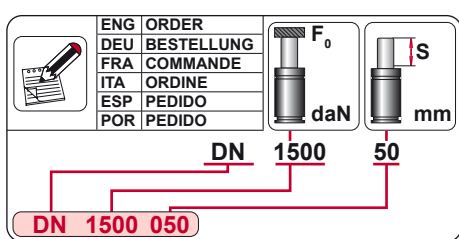
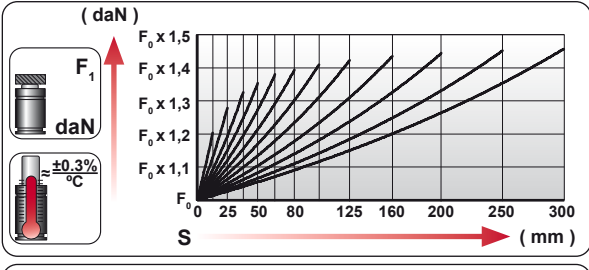

N₂

S_{max} < 100%

V_{max} 2 m/s

P_{min} (20°C)
P_{max} (20°C)

T_{min}
T_{max}

600 CP-

N ₂	S _{max} < 90%	V _{max} 2 m/s	bar psi 20 290	bar psi 150 2175	°C °F 0 32	°C °F 80 176	600 CP-
----------------	------------------------	------------------------	-------------------	---------------------	---------------	-----------------	---------

AZOL GAS DN 1500

150 DAMPED AT STROKE FINAL MILLIMETERS

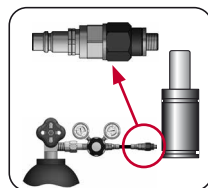
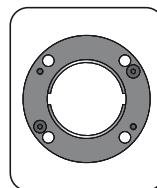
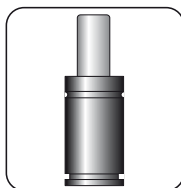

CODE	DN 1500 050	KIT S-XXXXXXX KIT C-XXXXXXX	A14-075	18 CG 1-Q
ENG ORDER	GAS SPRING	REPAIR KIT	FLANGE	CHARGING ADAPTER
DEU BESTELLUNG	GASDRUCKFEDER	ERSATZTEILSATZ	FLANSCH	LADEADAPTER
FRA COMMANDE	RESSORT À GAZ	KIT DE RÉPARATION	BRIDE	RACCORD DE CHARGE
ITA ORDINE	CILINDRO AD AZOTO	KIT DI MANUTENZIONE	FLANGE	ADATTATORE DI CARICO
ESP PEDIDO	RESORTE DE GAS	KIT DE REPARACION	BRIDA	ADAPTADOR DE CARGA
POR PEDIDO	CILINDRO DE GÁS	KIT DE MANUTENÇÃO	FLANGE	ADAPTADOR DE CARGA

DN 1500 MOUNTS

ISO

**AZOL
GAS**

A14-075

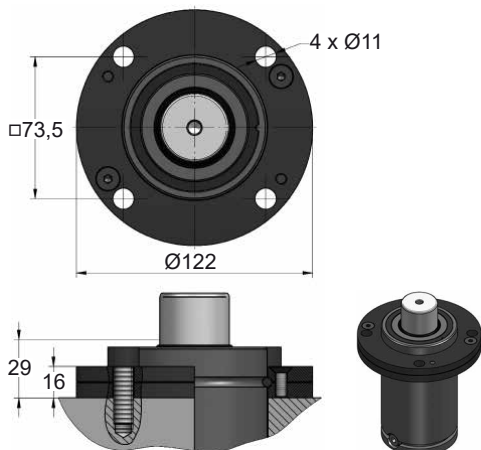

A34-075

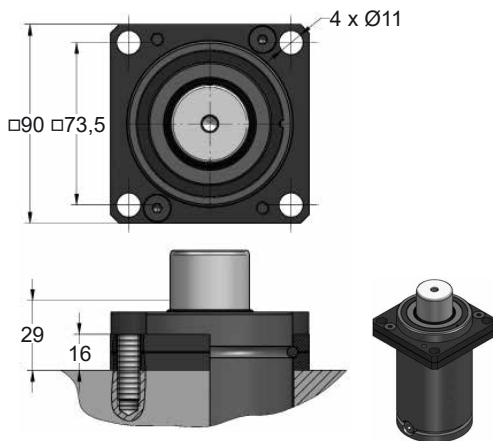

B21-075

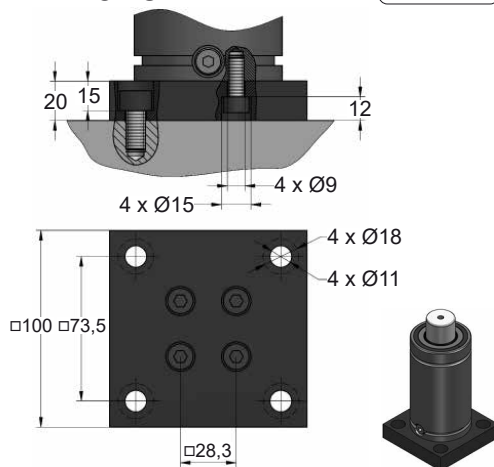

B76-075

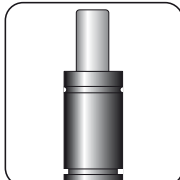
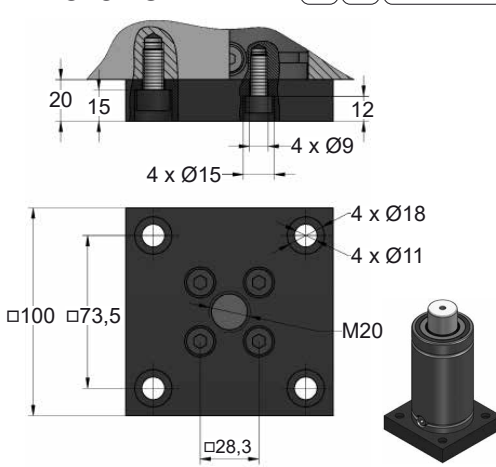

SEAL

KIT S-XXXXXXX

CARTRIDGE

KIT C-XXXXXXX

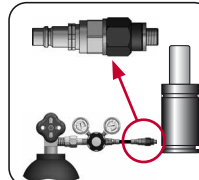
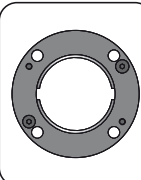

CODE

DN 1500 050

KIT S-XXXXXXX
KIT C-XXXXXXX

A14-075

18 CG 1-Q

 ENG ORDER
 DEU BESTELLUNG
 FRA COMMANDE
 ITA ORDINE
 ESP PEDIDO
 POR PEDIDO

 GAS SPRING
 GASDRUCKFEDER
 RESSORT À GAZ
 CILINDRO AD AZOTO
 RESORTE DE GAS
 CILINDRO DE GAS

 REPAIR KIT
 ERSATZTEILSATZ
 KIT DE RÉPARATION
 KIT DI MANUTENZIONE
 KIT DE REPARACION
 KIT DE MANUTENÇÃO

 FLANGE
 FLANSCH
 BRIDE
 FLANGE
 BRIDA
 FLANGE

 CHARGING ADAPTER
 LADEADAPTER
 RACCOD DE CHARGE
 ADATTATORE DI CARICO
 ADAPTADOR DE CARGA
 ADAPTADOR DE CARGA

150

C05-075

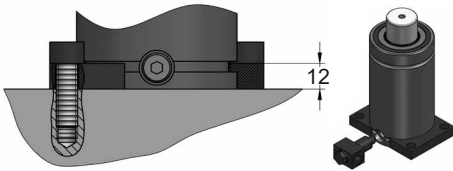
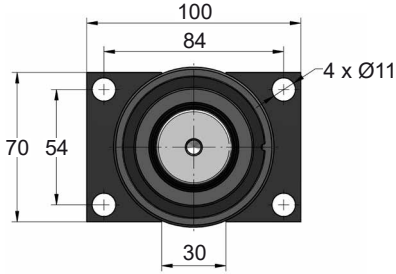

C20-075

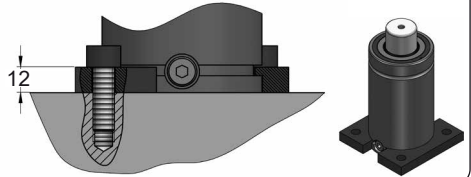
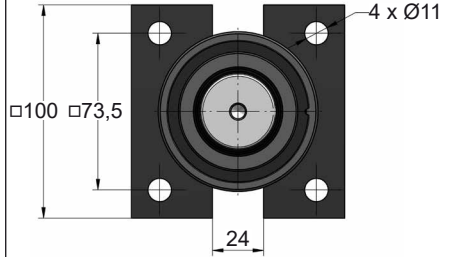

D02-075

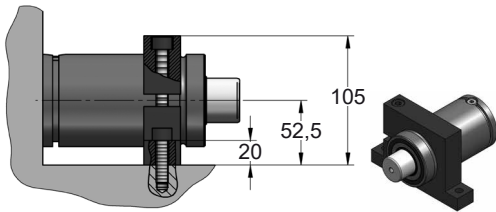
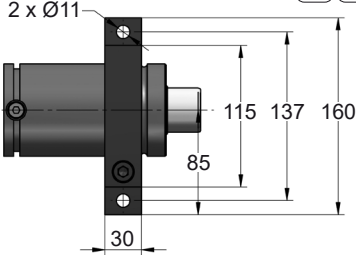

D67-075

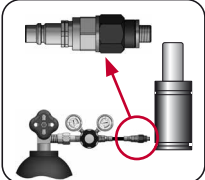
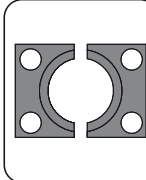
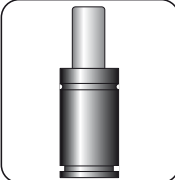
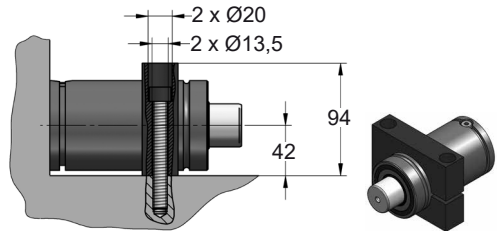
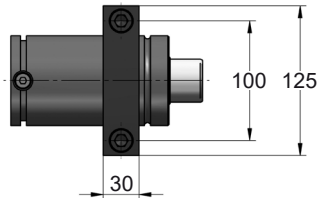

CODE	DN 1500 050	KIT S-XXXXXXX KIT C-XXXXXXX	C05-075	18 CG 1-Q
ENG ORDER	GAS SPRING	REPAIR KIT	FLANGE	CHARGING ADAPTER
DEU BESTELLUNG	GASDRUCKFEDER	ERSATZTEILSATZ	FLANSCHEN	LADEADAPTER
FRA COMMANDE	RESSORT À GAZ	KIT DE RÉPARATION	BRIDE	RACCORD DE CHARGE
ITA ORDINE	CILINDRO AD AZOTO	KIT DI MANUTENZIONE	FLANGE	ADATTATORE DI CARICO
ESP PEDIDO	RESORTE DE GAS	KIT DE REPARACION	BRIDA	ADAPTADOR DE CARGA
POR PEDIDO	CILINDRO DE GÁS	KIT DE MANUTENÇÃO	FLANGE	ADAPTADOR DE CARGA

DN 3000

150 DAMPED AT STROKE FINAL MILLIMETERS

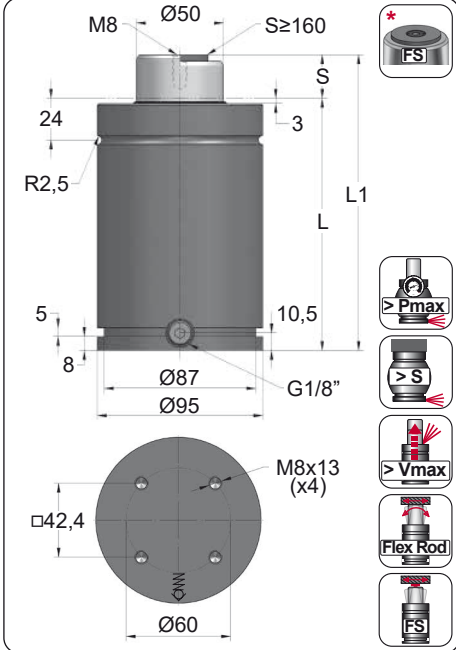

ORDER	S (mm)	L1 ±0,25 (mm)	L (mm)	Kg.
DN 3000 012	12.7	145.4	132.7	5.28
DN 3000 025	25	170	145	5.60
DN 3000 038	38	196	158	5.94
DN 3000 050	50	220	170	6.25
DN 3000 063	63.5	247	183.5	6.60
DN 3000 080	80	280	200	7.03
DN 3000 100	100	320	220	7.55
DN 3000 125	125	370	245	8.20
DN 3000 160 *	160	440	280	9.11
DN 3000 200 *	200	520	320	10.15
DN 3000 250 *	250	620	370	11.46
DN 3000 300 *	300	720	420	12.76

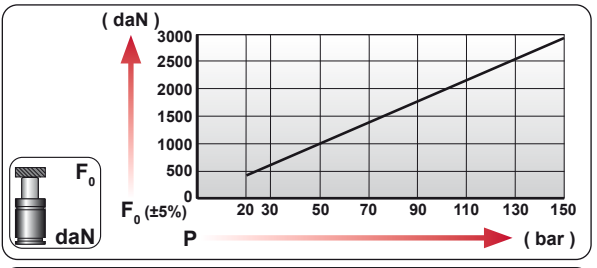

CODE	Pressure (bar)	Pressure (psi)	Force F ₀ (daN)	Force F ₁ (daN)
DN 3000 050	150	2175	2945	4180

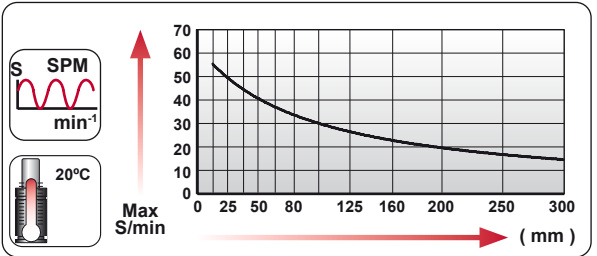
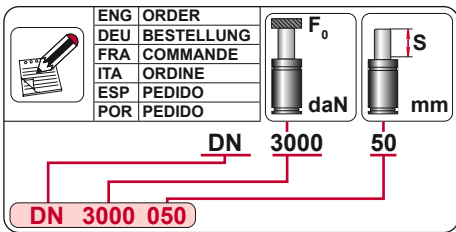
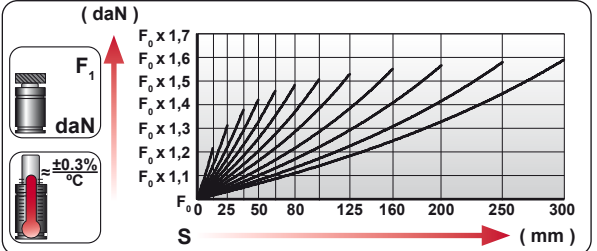

N₂

S_{max} < 90%

V_{max} 2 m/s

P_{min} (20°C)
P_{max} (20°C)

T_{min}
T_{max}

600 CP-

N ₂	S _{max} < 90%	V _{max} 2 m/s	bar psi	bar psi	°C °F	°C °F	600 CP-
			20 290	150 2175	0 32	80 176	

AZOL GAS DN 3000

150 DAMPED AT STROKE FINAL MILLIMETERS

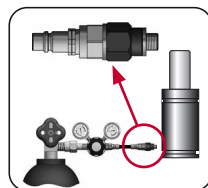
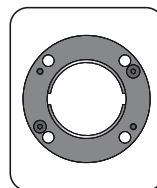
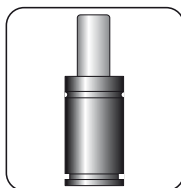

CODE	DN 3000 050	KIT S-XXXXXXX KIT C-XXXXXXX	A14-095	18 CG 1-Q
ENG ORDER	GAS SPRING	REPAIR KIT	FLANGE	CHARGING ADAPTER
DEU BESTELLUNG	GASDRUCKFEDER	ERSATZTEILSATZ	FLANSCHEN	LADEADAPTER
FRA COMMANDE	RESSORT À GAZ	KIT DE RÉPARATION	BRIDE	RACCORD DE CHARGE
ITA ORDINE	CILINDRO AD AZOTO	KIT DI MANUTENZIONE	FLANGE	ADATTATORE DI CARICO
ESP PEDIDO	RESORTE DE GAS	KIT DE REPARACION	BRIDA	ADAPTADOR DE CARGA
POR PEDIDO	CILINDRO DE GÁS	KIT DE MANUTENÇÃO	FLANGE	ADAPTADOR DE CARGA

DN 3000 MOUNTS

150

A14-095

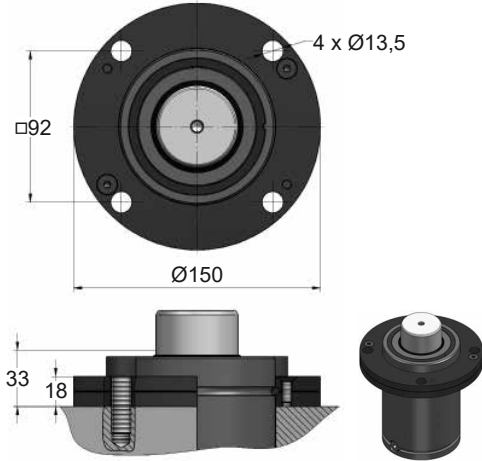

A34-095

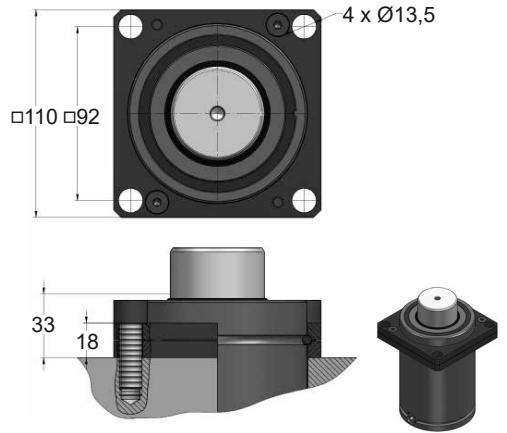

B21-095

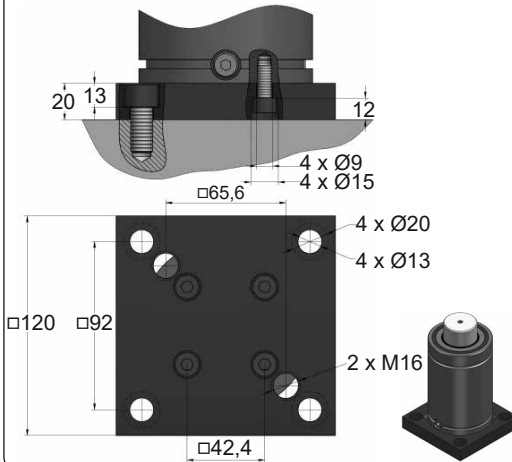

B76-095

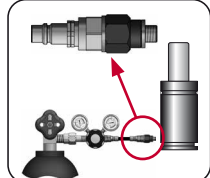
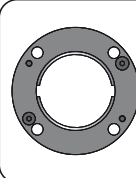
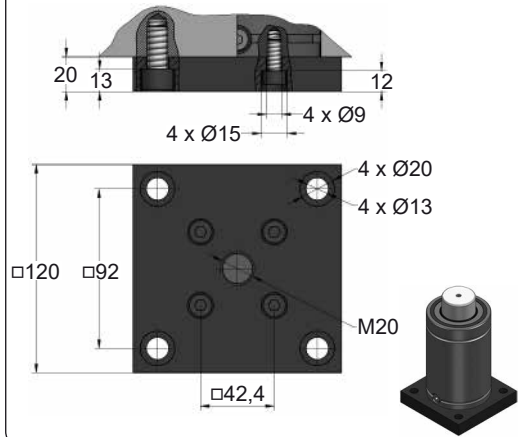

CODE	DN 3000 050	KIT S-XXXXXXX KIT C-XXXXXXX	A14-095	18 CG 1-Q
ENG ORDER	GAS SPRING	REPAIR KIT	FLANGE	CHARGING ADAPTER
DEU BESTELLUNG	GASDRUCKFEDER	ERSATZTEILSATZ	FLANSCHEN	LADEADAPTER
FRA COMMANDE	RESSORT À GAZ	KIT DE RÉPARATION	BRIDE	RACCORD DE CHARGE
ITA ORDINE	CILINDRO AD AZOTO	KIT DI MANUTENZIONE	FLANGE	ADATTATORE DI CARICO
ESP PEDIDO	RESORTE DE GAS	KIT DE REPARACION	BRIDA	ADAPTADOR DE CARGA
POR PEDIDO	CILINDRO DE GÁS	KIT DE MANUTENÇÃO	FLANGE	ADAPTADOR DE CARGA



DN 3000 MOUNTS

ISO

C05-095

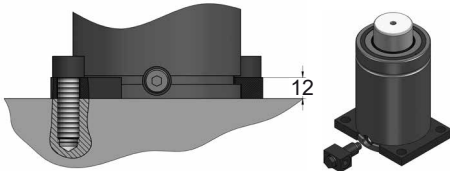
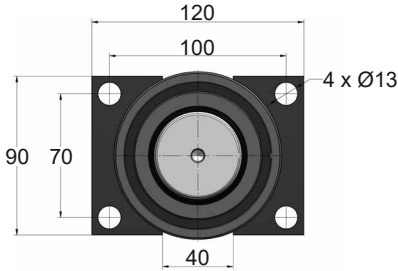

C20-095

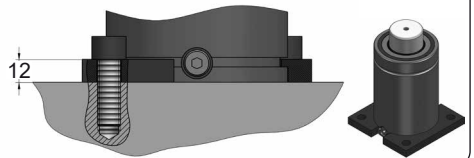
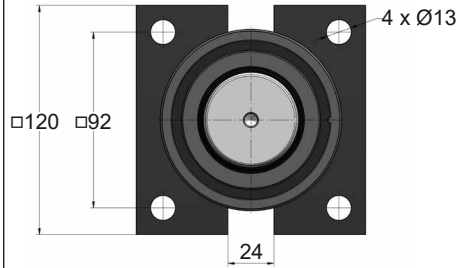

D02-095

2 x Ø13,5

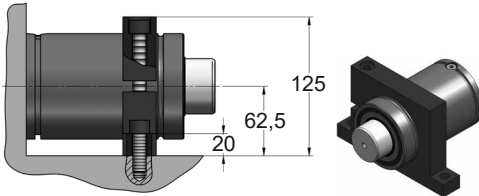
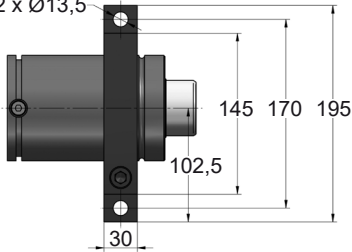

D67-095

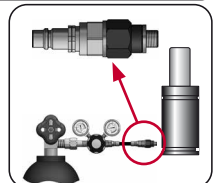
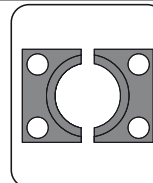
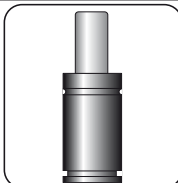
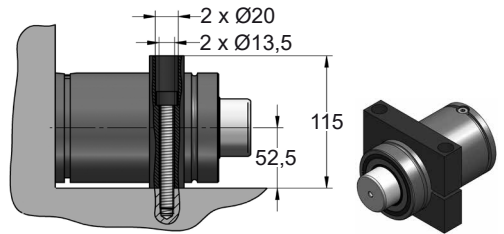
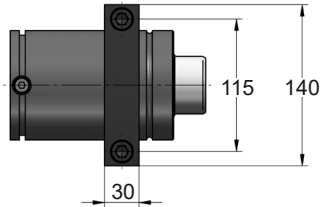

CODE	DN 3000 050	KIT S-XXXXXXX KIT C-XXXXXXX	C05-095	18 CG 1-Q	
ENG	ORDER	GAS SPRING	REPAIR KIT	FLANGE	CHARGING ADAPTER
DEU	BESTELLUNG	GASDRUCKFEDER	ERSATZTEILSATZ	FLANSCHEN	LADEADAPTER
FRA	COMMANDE	RESSORT À GAZ	KIT DE RÉPARATION	BRIDE	RACCORD DE CHARGE
ITA	ORDINE	CILINDRO AD AZOTO	KIT DI MANUTENZIONE	FLANGE	ADATTATORE DI CARICO
ESP	PEDIDO	RESORTE DE GAS	KIT DE REPARACION	BRIDA	ADAPTADOR DE CARGA
POR	PEDIDO	CILINDRO DE GÁS	KIT DE MANUTENÇÃO	FLANGE	ADAPTADOR DE CARGA

DN 5000

150 DAMPED AT STROKE FINAL MILLIMETERS

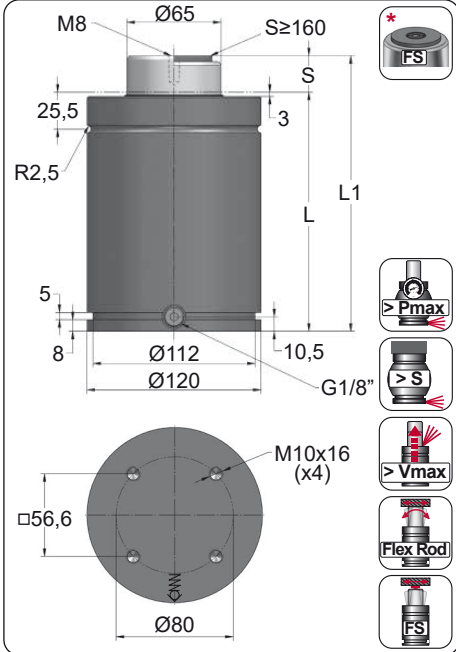

ORDER	S (mm)	L1 ±0,25 (mm)	L (mm)	Kg.
DN 5000 012	12.7	165.4	152.7	9.90
DN 5000 025	25	190	165	10.40
DN 5000 038	38	216	178	10.92
DN 5000 050	50	240	190	11.41
DN 5000 063	63.5	267	203.5	11.96
DN 5000 080	80	300	220	12.63
DN 5000 100	100	340	240	13.45
DN 5000 125	125	390	265	14.47
DN 5000 160 *	160	460	300	15.89
DN 5000 200 *	200	540	340	17.52
DN 5000 250 *	250	640	390	19.55
DN 5000 300 *	300	740	440	21.59

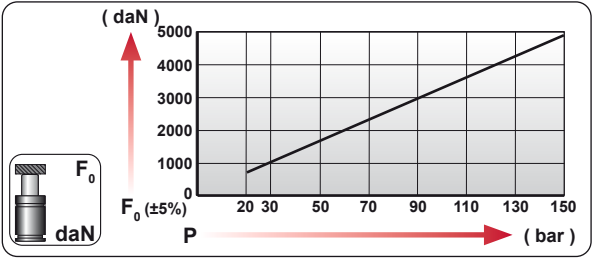

CODE				
		bar psi	daN	daN
DN 5000 050		150 2175	4980	7170

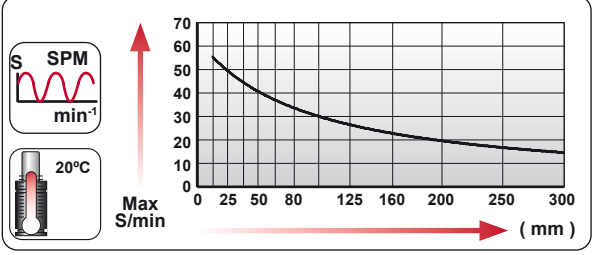
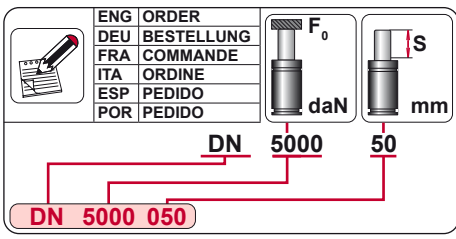
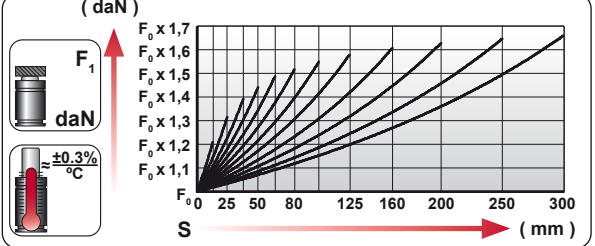

N₂

Smax < 90%

Vmax 2 m/s

Pmin (20°C) Pmax (20°C)

Tmin Tmax

600 CP-

N₂	Smax < 90%	Vmax 2 m/s	bar psi 20 290	bar psi 150 2175	°C °F 0 32	°C °F 80 176	600 CP-
----------------------	----------------------	-------------------	--------------------------	----------------------------	----------------------	------------------------	----------------

AZOL GAS DN 5000

150 DAMPED AT STROKE FINAL MILLIMETERS

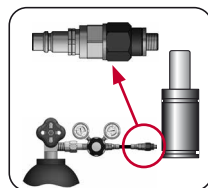
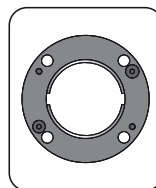
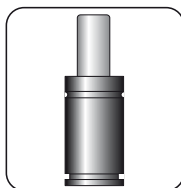

CODE	DN 5000 050	KIT S-XXXXXXX KIT C-XXXXXXX	A14-120	18 CG 1-Q
ENG ORDER	GAS SPRING	REPAIR KIT	FLANGE	CHARGING ADAPTER
DEU BESTELLUNG	GASDRUCKFEDER	ERSATZTEILSATZ	FLANSCHEN	LADEADAPTER
FRA COMMANDE	RESSORT À GAZ	KIT DE RÉPARATION	BRIDE	RACCORD DE CHARGE
ITA ORDINE	CILINDRO AD AZOTO	KIT DI MANUTENZIONE	FLANGE	ADATTATORE DI CARICO
ESP PEDIDO	RESORTE DE GAS	KIT DE REPARACION	BRIDA	ADAPTADOR DE CARGA
POR PEDIDO	CILINDRO DE GÁS	KIT DE MANUTENÇÃO	FLANGE	ADAPTADOR DE CARGA

DN 5000 MOUNTS

ISO

A14-120

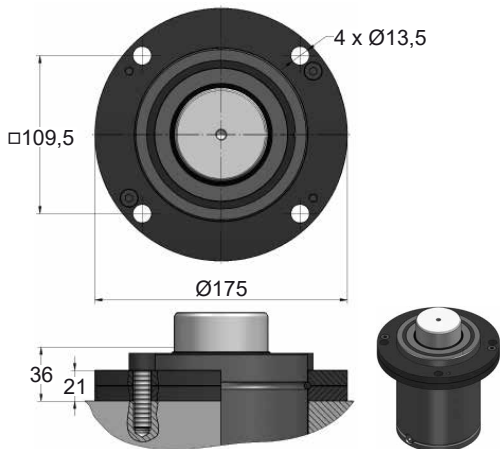

A34-120

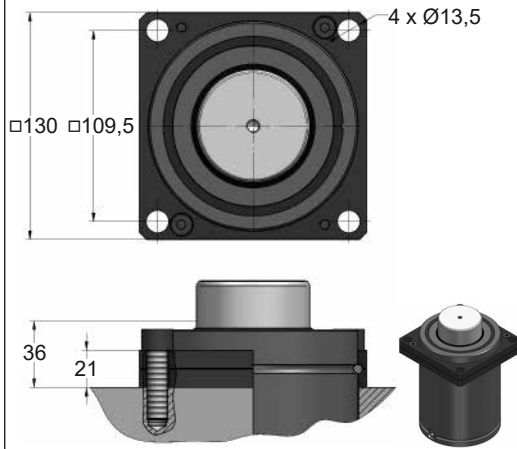

B21-120

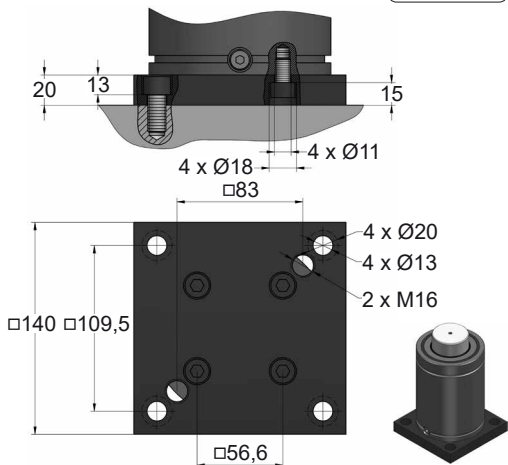

B76-120

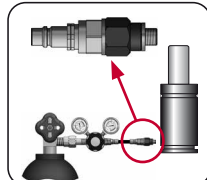
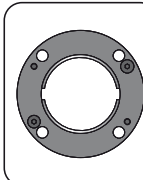
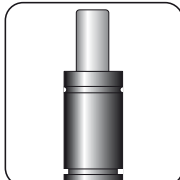
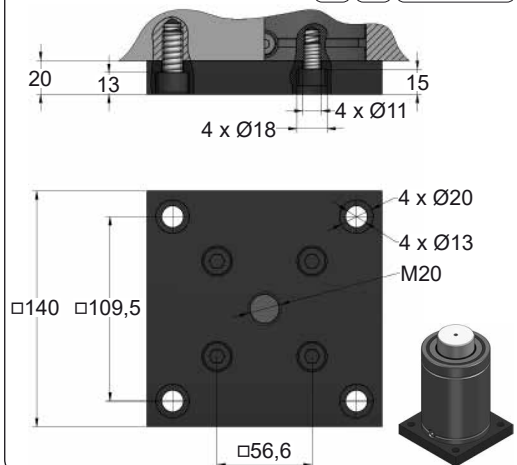

CODE	DN 5000 050	KIT S-XXXXXXX KIT C-XXXXXXX	A14-120	18 CG 1-Q
ENG ORDER	GAS SPRING	REPAIR KIT	FLANGE	CHARGING ADAPTER
DEU BESTELLUNG	GASDRUCKFEDER	ERSATZTEILSATZ	FLANSCHEN	LADEADAPTER
FRA COMMANDE	RESSORT À GAZ	KIT DE RÉPARATION	BRIDE	RACCORD DE CHARGE
ITA ORDINE	CILINDRO AD AZOTO	KIT DI MANUTENZIONE	FLANGE	ADATTATORE DI CARICO
ESP PEDIDO	RESORTE DE GAS	KIT DE REPARACION	BRIDA	ADAPTADOR DE CARGA
POR PEDIDO	CILINDRO DE GAS	KIT DE MANUTENÇÃO	FLANGE	ADAPTADOR DE CARGA



DN 5000 MOUNTS

ISO

C05-120

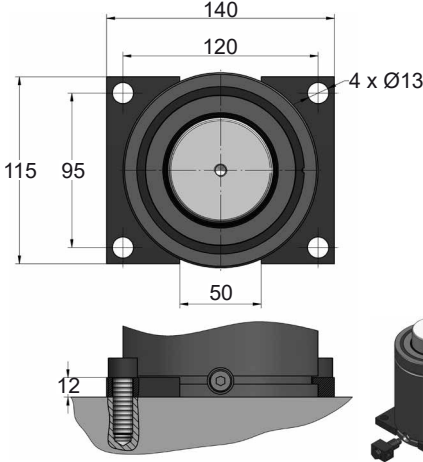

C20-120

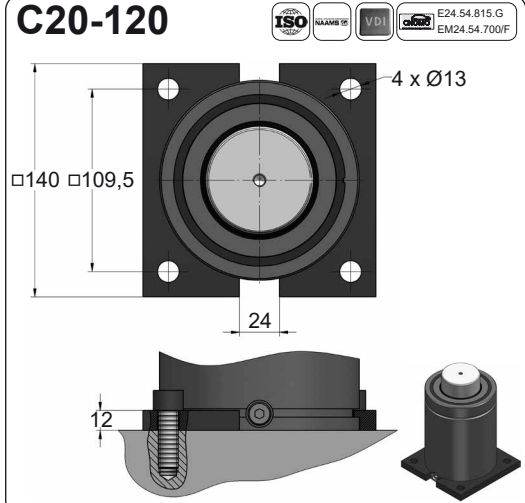

D02-120

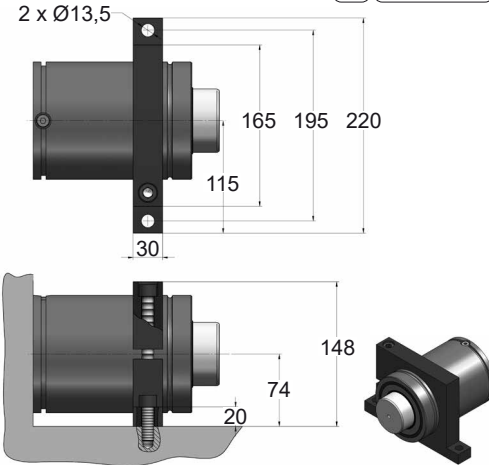

D67-120

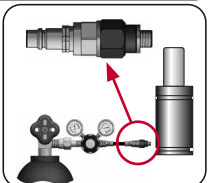
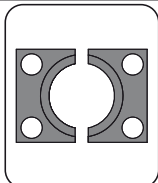
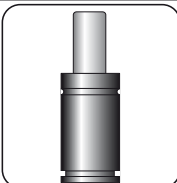
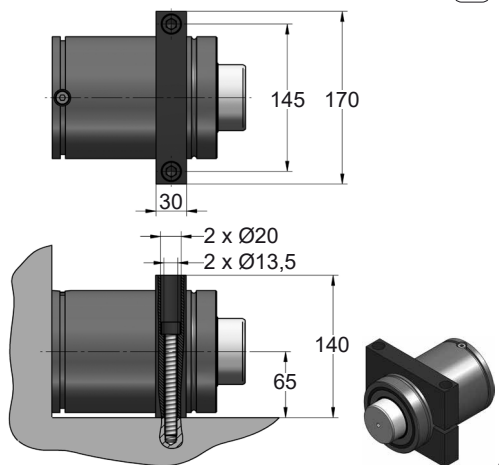

CODE	DN 5000 050	KIT S-XXXXXXX KIT C-XXXXXXX	C05-120	18 CG 1-Q
ENG ORDER	GAS SPRING	REPAIR KIT	FLANGE	CHARGING ADAPTER
DEU BESTELLUNG	GASDRUCKFEDER	ERSATZTEILSATZ	FLANSCHEN	LADEADAPTER
FRA COMMANDE	RESSORT À GAZ	KIT DE RÉPARATION	BRIDE	RACCORD DE CHARGE
ITA ORDINE	CILINDRO AD AZOTO	KIT DI MANUTENZIONE	FLANGE	ADATTATORE DI CARICO
ESP PEDIDO	RESORTE DE GAS	KIT DE REPARACION	BRIDA	ADAPTADOR DE CARGA
POR PEDIDO	CILINDRO DE GÁS	KIT DE MANUTENÇÃO	FLANGE	ADAPTADOR DE CARGA

DN 7500

150 DAMPED AT STROKE FINAL MILLIMETERS

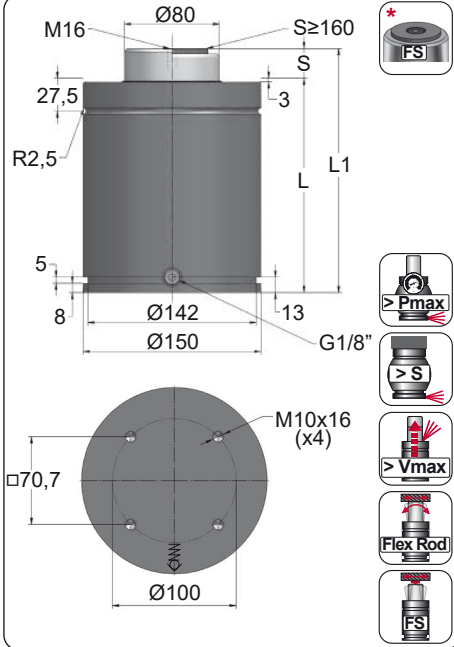

ORDER	S (mm)	L1 ±0,25 (mm)	L (mm)	Kg.
DN 7500 012	12.7	180.4	167.7	17.20
DN 7500 025	25	205	180	17.98
DN 7500 038	38	231	193	18.80
DN 7500 050	50	255	205	19.56
DN 7500 063	63.5	282	218.5	20.41
DN 7500 080	80	315	235	21.46
DN 7500 100	100	355	255	22.72
DN 7500 125	125	405	280	24.30
DN 7500 160 *	160	475	315	26.51
DN 7500 200 *	200	555	355	29.04
DN 7500 250 *	250	655	405	32.20
DN 7500 300 *	300	755	455	35.36

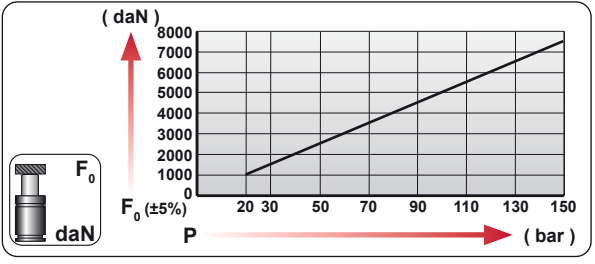

CODE	Pressure (bar)	Pressure (psi)	F ₀ (daN)	F ₁ (daN)
DN 7500 050	150	2175	7540	10960

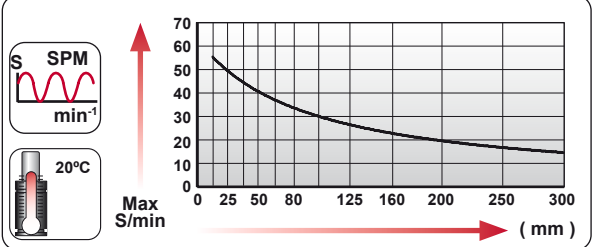
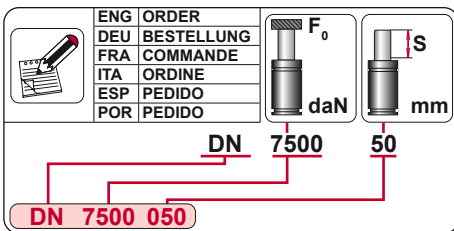
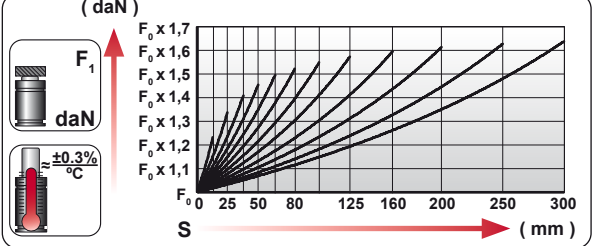

N₂

S_{max} < 90%

V_{max} 2 m/s

P_{min} (20°C) P_{max} (20°C)

T_{min} T_{max}

600 CP-

bar	psi	bar	psi	°C	°F	°C	°F
20	290	150	2175	0	32	80	176

AZOL GAS DN 7500

150 DAMPED AT STROKE FINAL MILLIMETERS

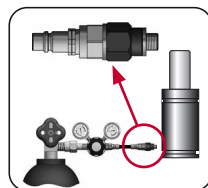
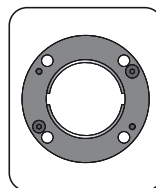
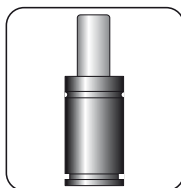

CODE	DN 7500 050	KIT S-XXXXXXX KIT C-XXXXXXX	A14-150	18 CG 1-Q
ENG ORDER	GAS SPRING	REPAIR KIT	FLANGE	CHARGING ADAPTER
DEU BESTELLUNG	GASDRUCKFEDER	ERSATZTEILSATZ	FLANSCH	LADEADAPTER
FRA COMMANDE	RESSORT À GAZ	KIT DE RÉPARATION	BRIDE	RACCORD DE CHARGE
ITA ORDINE	CILINDRO AD AZOTO	KIT DI MANUTENZIONE	FLANGE	ADATTATORE DI CARICO
ESP PEDIDO	RESORTE DE GAS	KIT DE REPARACION	BRIDA	ADAPTADOR DE CARGA
POR PEDIDO	CILINDRO DE GÁS	KIT DE MANUTENÇÃO	FLANGE	ADAPTADOR DE CARGA

DN 7500 MOUNTS



ISO

A14-150

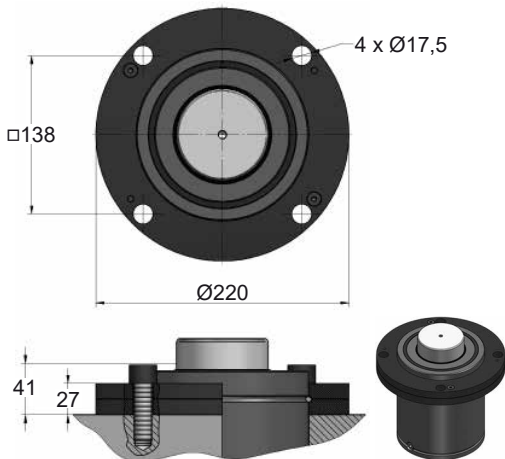

A34-150

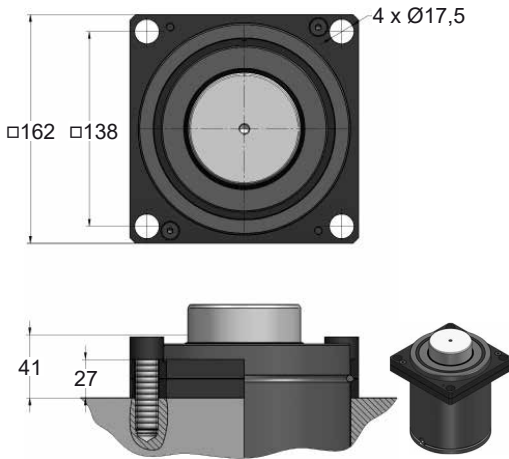

B21-150

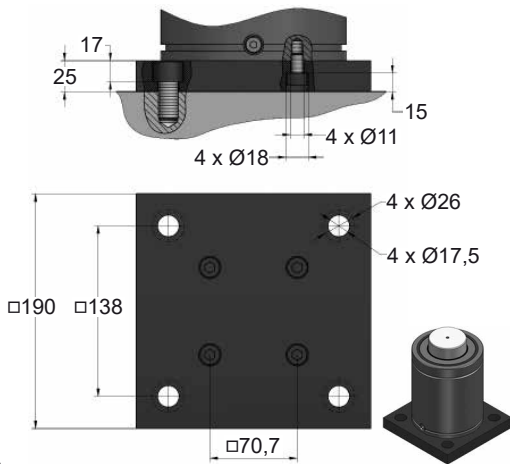

B76-150

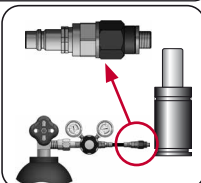
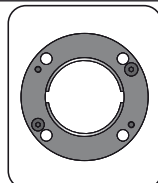
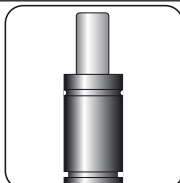
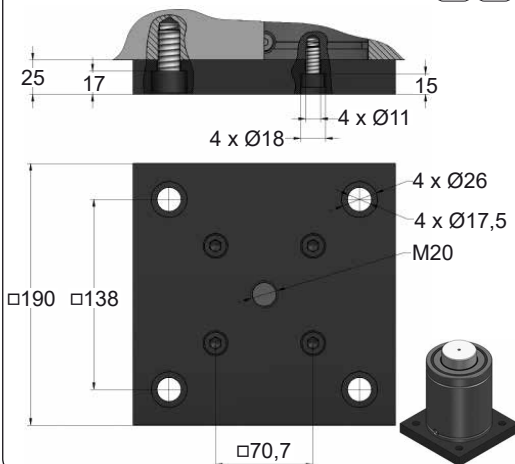

CODE	DN 7500 050	KIT S-XXXXXXX KIT C-XXXXXXX	A14-150	18 CG 1-Q
ENG ORDER	GAS SPRING	REPAIR KIT	FLANGE	CHARGING ADAPTER
DEU BESTELLUNG	GASDRUCKFEDER	ERSATZTEILSATZ	FLANSCHEN	LADEADAPTER
FRA COMMANDE	RESSORT À GAZ	KIT DE RÉPARATION	BRIDE	RACCORD DE CHARGE
ITA ORDINE	CILINDRO AD AZOTO	KIT DI MANUTENZIONE	FLANGE	ADATTATORE DI CARICO
ESP PEDIDO	RESORTE DE GAS	KIT DE REPARACION	BRIDA	ADAPTADOR DE CARGA
POR PEDIDO	CILINDRO DE GÁS	KIT DE MANUTENÇÃO	FLANGE	ADAPTADOR DE CARGA



DN 7500 MOUNTS

ISO

C05-150

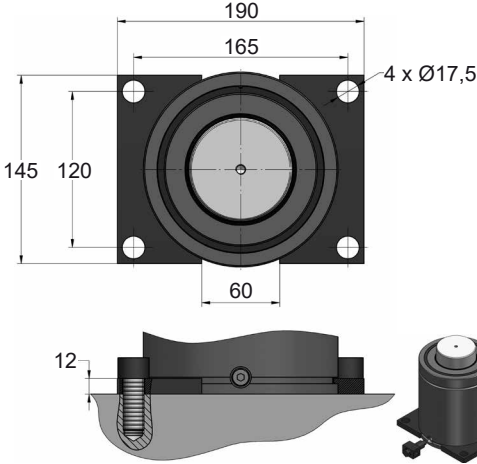

C20-150

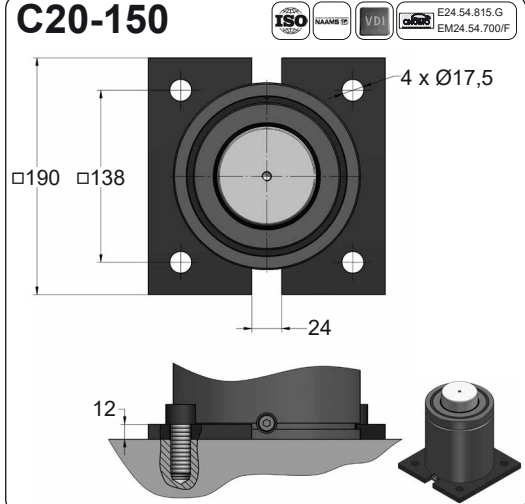

D02-150

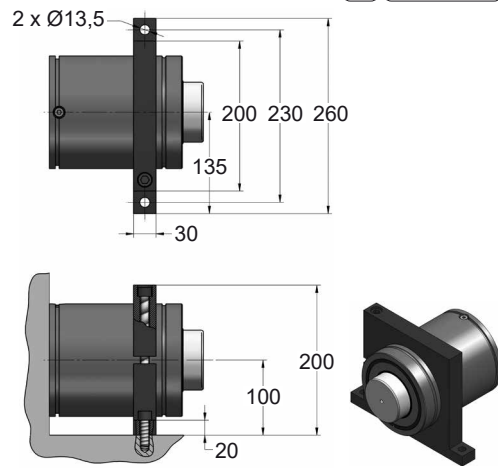

D67-150

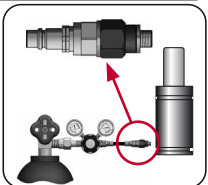
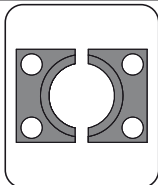
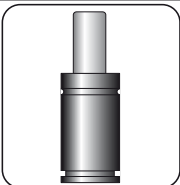
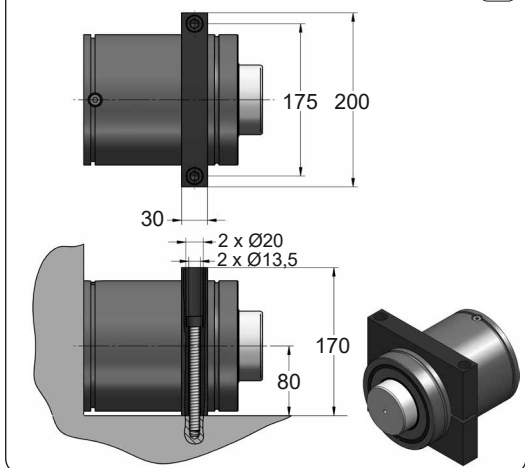

CODE	DN 7500 050	KIT S-XXXXXXX KIT C-XXXXXXX	C05-150	18 CG 1-Q
ENG ORDER	GAS SPRING	REPAIR KIT	FLANGE	CHARGING ADAPTER
DEU BESTELLUNG	GASDRUCKFEDER	ERSATZTEILSATZ	FLANSCHEN	LADEADAPTER
FRA COMMANDE	RESSORT À GAZ	KIT DE RÉPARATION	BRIDE	RACCORD DE CHARGE
ITA ORDINE	CILINDRO AD AZOTO	KIT DI MANUTENZIONE	FLANGE	ADATTATORE DI CARICO
ESP PEDIDO	RESORTE DE GAS	KIT DE REPARACION	BRIDA	ADAPTADOR DE CARGA
POR PEDIDO	CILINDRO DE GÁS	KIT DE MANUTENÇÃO	FLANGE	ADAPTADOR DE CARGA





Landalucía, 7, P.I. Júndiz
01015 Vitoria-Gasteiz
Tel.: +34 945 290 010
Fax: +34 945 290 381

azolgas@azolgas.com
www.azolgas.com